



Sepro mixer with CHV high viscosity impellers



Sepro mixer with CHF impellers typically used for solids suspension and blending applications



Sepro Mixing angular offset mixer for use in unbaffled tanks

At **Sepro Mixing & Pumping** we operate on the old style values of Trust, Honesty, Integrity and Value.

We believe that our customers are equal partners in our business and are entitled to an open and informative evaluation of their problems, solutions, and projects.

For more information about products in our mixing and pumping range, visit our website or contact us at the following:

HEAD OFFICE:

#114-19100 Airport Way, Pitt Meadows, BC V3Y 0E2 | Canada
(+1) 604 465 9920 | mixing@seprosystems.com

www.mixing.seprosystems.com



SEPRO products are proudly made in Canada.



sepro
mixing & pumping



sepro
mixing & pumping

**Specialists in
Fluid Mixing**

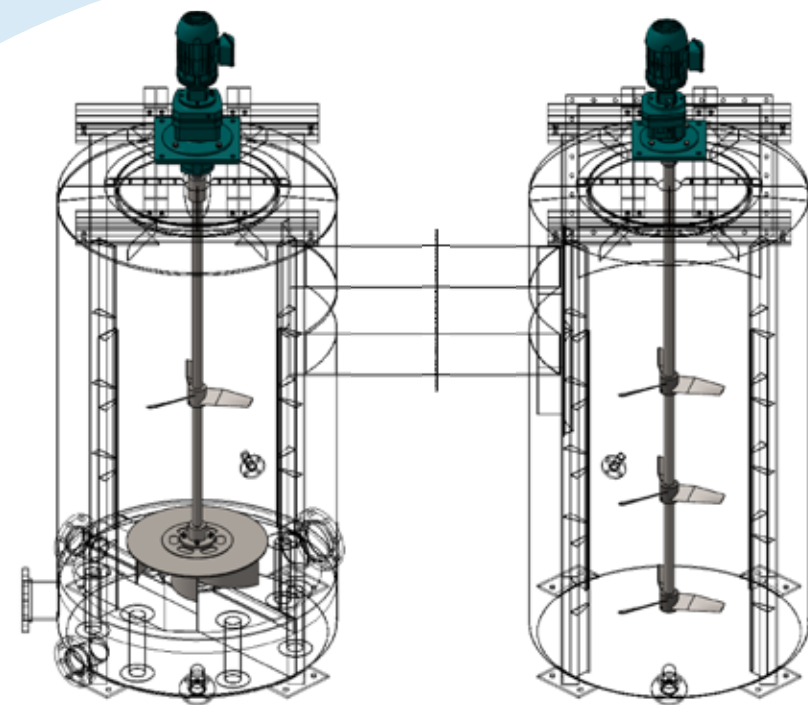

Example of Sepro Mixing Primary Pumper and Secondary Agitators for solvent extraction

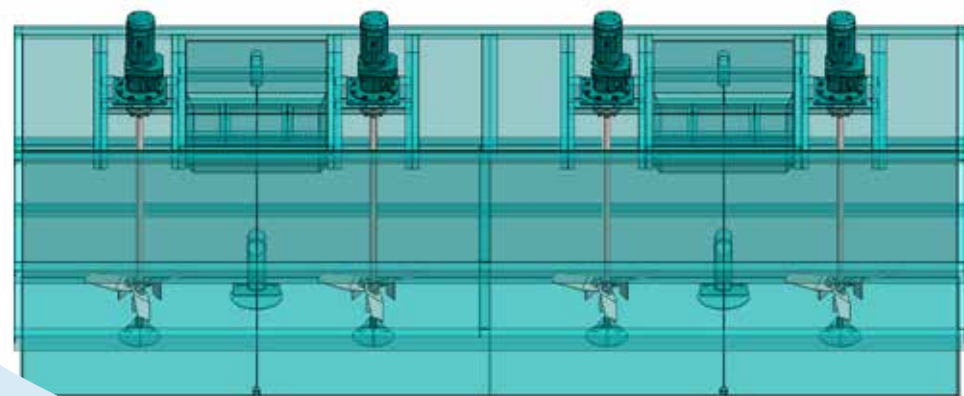

Series of Sepro mixers for a salt brine production system

Sepro makes **AGITATORS FOR any duty!**

From gas dispersion to solids suspension - **Sepro Mixing & Pumping's** innovative agitation design is the future in quality and performance for any mixing application. Our designers use decades of experience and technical expertise to customize mixing systems for the mining, chemical, pharmaceutical, paper and waste and water treatment industries. Whatever the application, there is a **Sepro Mixing & Pumping** agitator ready for the challenge.

Contact us today and allow our highly qualified **Sepro Mixing & Pumping** design & engineering team to help design the most efficient agitator for your application.

Fluid Mixing Products:

- **LARGE TOP-ENTRY AGITATORS**
- **SMALL TOP-ENTRY AGITATORS**
- **PORTABLE AGITATORS**
- **TOTE MIXERS**
- **PNEUMATIC MIXERS**
- **SIDE ENTRY MIXERS**



SEPRO Agitators are 100% Canadian Manufactured!



MINERALS PROCESSING
Leaching, CIP, CIL, Neutralisation, Lime make-up & storage, and general solids suspension.



PETROCHEMICALS
Top and side entry mixers for oil and gas storage, chemical make-up & blending, and mud mixing.



GAS DISPERSION
High efficiency gas dispersion impellers allowing 4x greater gas flow than conventional aerofoils.



HIGH VISCOSITY MIXING
Specialised high solidity and helical impellers for mixing viscous materials from 5,000 - 500,000 cps.



SOLVENT EXTRACTION
Primary pump mixers and secondaries for efficient operation in solvent extraction settlers.



BLENDED & SOLIDS SUSPENSION
High efficiency agitators & aerofoil impellers using low power for general blending & solids suspension.



WASTE & WATER TREATMENT
Anaerobic mixing, make-up of water treatment chemicals and flocculants.



PULP & PAPER MIXING
Side entry & top entry mixers for stock chests, starch and chemical make-up, and coating preparations.

Product \ Application	Minerals Processing	Petrochemicals	Gas Dispersion	High Viscosity Fluids	Solvent Extraction	Blending	Waste & Water Treatment	Pulp & Paper Handling
Large Top-Entry Agitators	✓	✓	✓	✓	✓	✓	✓	✓
Small Top-Entry Agitators	✓	✓		✓	✓	✓	✓	
Side Entry Agitators		✓				✓	✓	✓
Portable Agitators	✓	✓		✓		✓	✓	
Tote Mixers				✓		✓		
Pneumatic Mixers		✓				✓		

General Application Suitability Chart

Contact Sepro Mixing & Pumping for exact product selection and specifications.

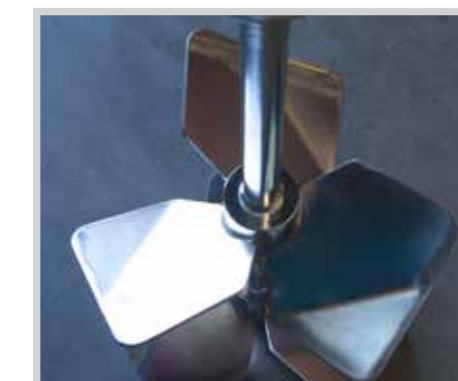

Sepro Mixing high solidity impeller



Sepro Mixing ammonium nitrate agitators



Sepro Mixing 11 1/2 ft (3500 mm dia) high solidity impeller installed

Call Sepro Mixing today for immediate service: +1(604) 465 9920