

1



SEPRO BLACKHAWK 100 CONE CRUSHERS

APPLICATIONS

Mining

- Ball mill feed, pebble crushing

Aggregates

- Road, concrete, asphalt, mining haul roads
- Secondary or tertiary crushing applications

KEY ADVANTAGES

- High quality components
- Durable and compact design
- Readily available spare parts
- Fast delivery schedule
- High capacity for small head diameter (690 mm)
- High speed, eccentric throw
- High horsepower motor (90 kW)
- Does not require sheaves and v-belts
- Simplified operation and maintenance
- Variable speed drive included
- Patented (pending) tension lock bolt arrangement creates tension around top bolt for liner retention
- Dual action hydraulic cylinder and hydraulic adjustment

OPTIMIZED DESIGN PAIRED WITH PROVEN DURABILITY

The **Sepro Blackhawk 100 Cone Crusher** is a modern, hydraulically operated cone crusher designed to be simple, rugged and effective for heavy duty mining and aggregate applications. The combination of the speed and eccentric throw of the crusher provides fine crushing capability and high capacity in a very compact design. The Blackhawk is capable of being applied as a secondary or tertiary crusher as well as a pebble crusher.

The Blackhawk 100 is driven directly via a flexible coupling to the electric drive motor. This arrangement eliminates the need for sheaves and v-belts, allowing for simplified operation and maintenance. A variable speed drive package is included to optimize the speed of the machine to the given liner profile, feed and production conditions.

The patented (pending) lock bolt design for holding the cone liner in place eliminates the need for a torch or burning ring. Any potential for damage during liner changes is also eliminated.

In the event of tramp material entering the crusher, the hydraulic cylinder allows for the release of the material. For larger material the cylinder may be engaged to clear the chamber.



SEPRO BLACKHAWK 100 CONE CRUSHERS

BLACKHAWK 100 SPECIFICATIONS

TONNES / HOUR	CLOSED SETTING (mm)							POWER (kW)	WEIGHT (Kg)	
	8 (5/16")	10 (3/8")	13 (1/2")	16 (5/8")	19 (3/4")	22 (7/8")	25 (1")			32 (1 1/4")
Mtph	45-65	50-75	55-85	65-95	70-100	75-105	80-115	95-145	90	7700

CRUSHER CAVITY SELECTION	MAXIMUM FEED OPENING (mm)	MINIMUM DISCHARGE SETTING (mm)
FINE	105	8
MEDIUM	119	10
COARSE	142	16

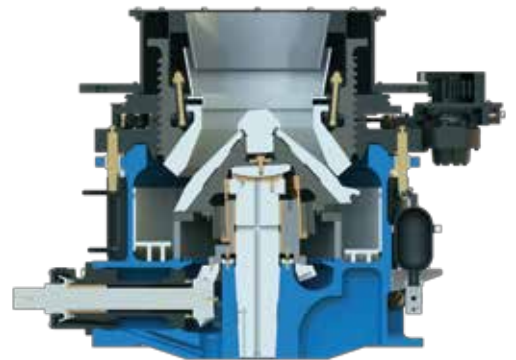
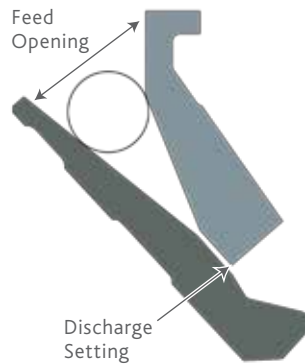

Note: Specifications are job/project dependent and/or application specific. Please check with Sepro sales representative.



Sepro Mineral Systems Corp.
 9850 201 Street, Langley, British Columbia, Canada V1M 4A3
 Office: +[1] 604.888.5568 • Fax: +[1] 604.888.5521 • Toll free: +[1] 800.990.5568 North America
 sepro@seprosystems.com • www.seprosystems.com

