

SPLIT SPHERICAL ROLLER BEARINGS

Quality

Our state of the art manufacturing and quality control process allows us to manufacture customized bearings with one of the highest quality on the market. All key processes, from bearing design through raw material selection, forging, heat treatment, grinding to assembly operation, are fully controlled and documented. The complete quality control process undergoes a thorough inspection, where 100% of parts are inspected during and after manufacturing process. Additionally we inspect at random in our main QC Lab before final shipment to the customer.

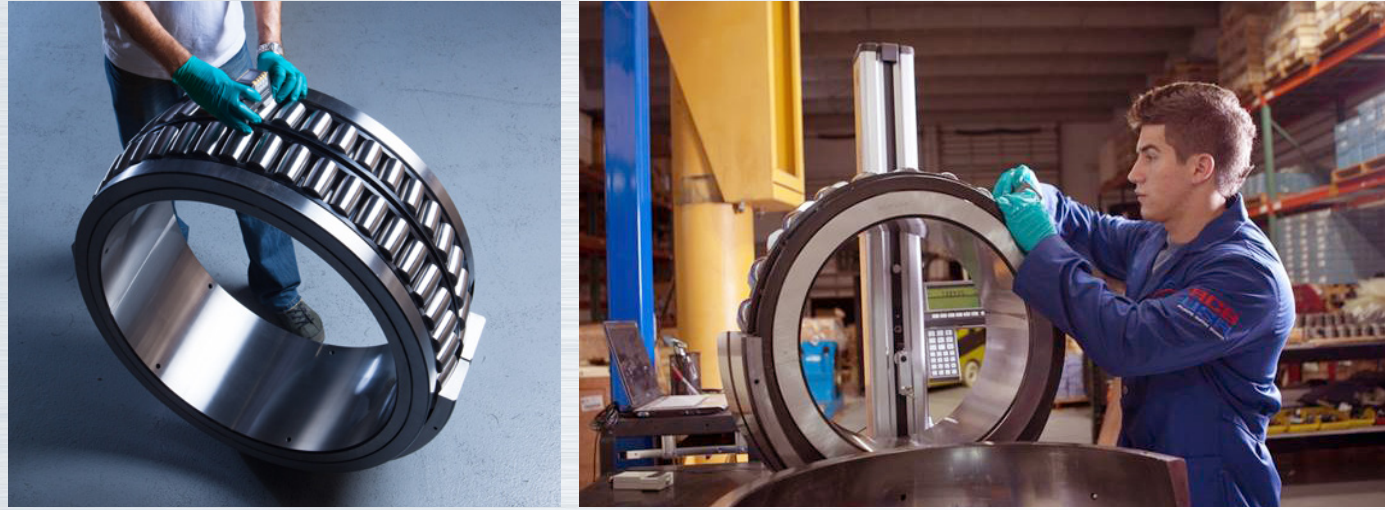

Aftermarket Services

Our maximum goal is not only to provide high quality customized bearings but to also to offer personalized aftermarket services including mounting procedures and recommendations on site mounting supervision and regular inspection assistance.

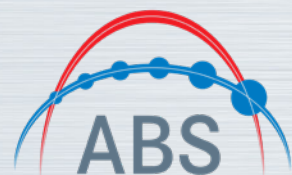
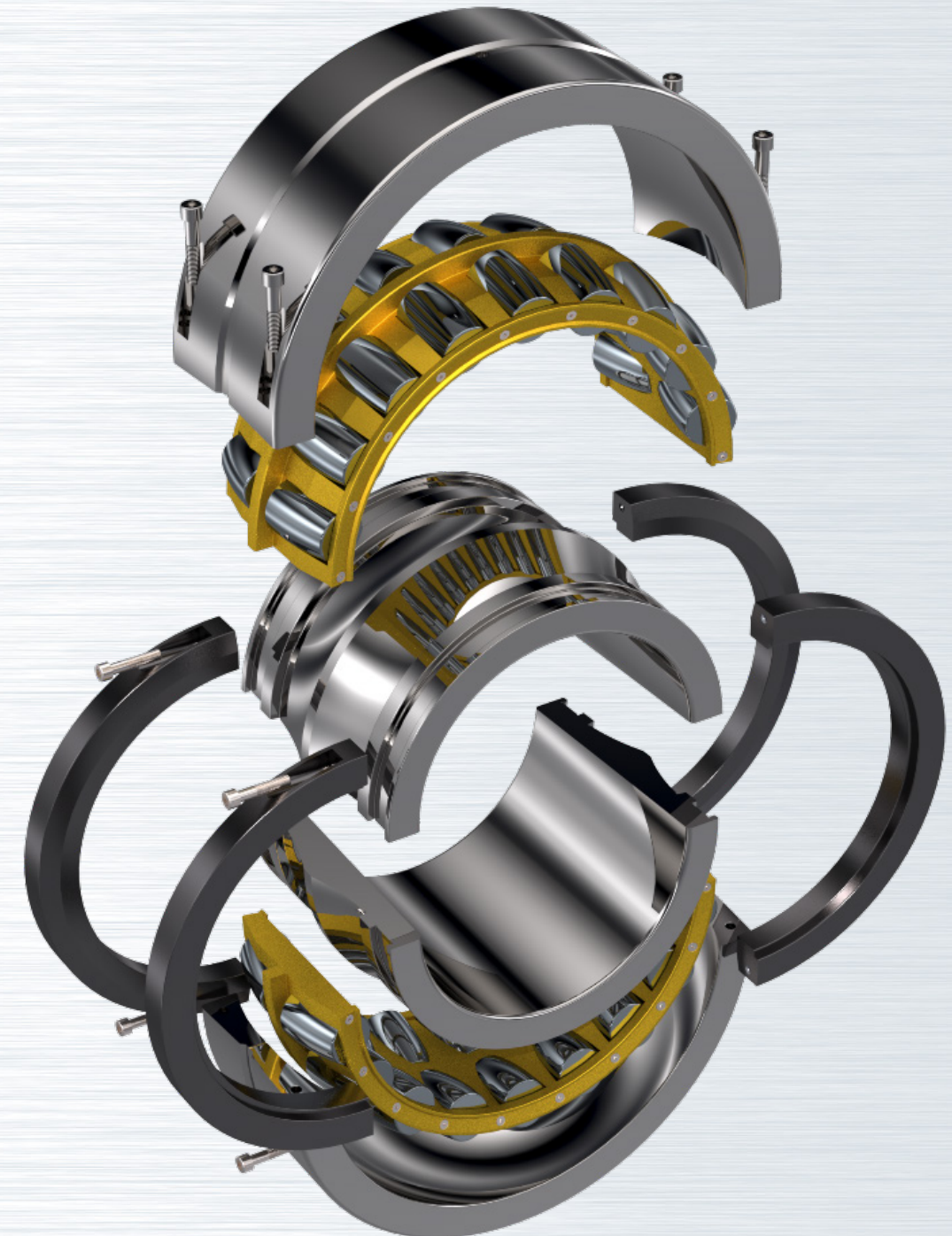

ATLANTIC BEARING SERVICES LLC. 8208 NW 30th Terrace Miami, FL 33122 USA
ph 1.305.592.4404 / fax 1.305.592.4540 / sales@atlantic-bearing.com / www.atlantic-bearing.com

Argentina - Bolivia - Brazil - Chile - China - Colombia - Costa Rica - Dominican Republic - Ecuador
El Salvador - Guatemala - Honduras - Italy - Mexico - Nicaragua - Panama - Peru - Spain - USA

Argentina - Bolivia - Brazil - Chile - China - Colombia - Costa Rica - Dominican Republic - Ecuador
El Salvador - Guatemala - Honduras - Italy - Mexico - Nicaragua - Panama - Peru - Spain - USA

ACB Bearings emerges as a new brand of highly engineered bearings. Our philosophy is to offer our customer a personalized solution that includes pricing, quick deliveries, small scale production and changes to standard bearing designs for a specific customer's need. Our success has been enhanced by maintaining a consistent quality standard throughout the wide range of special bearings manufactured.

ACB Split Spherical Roller Bearing Design

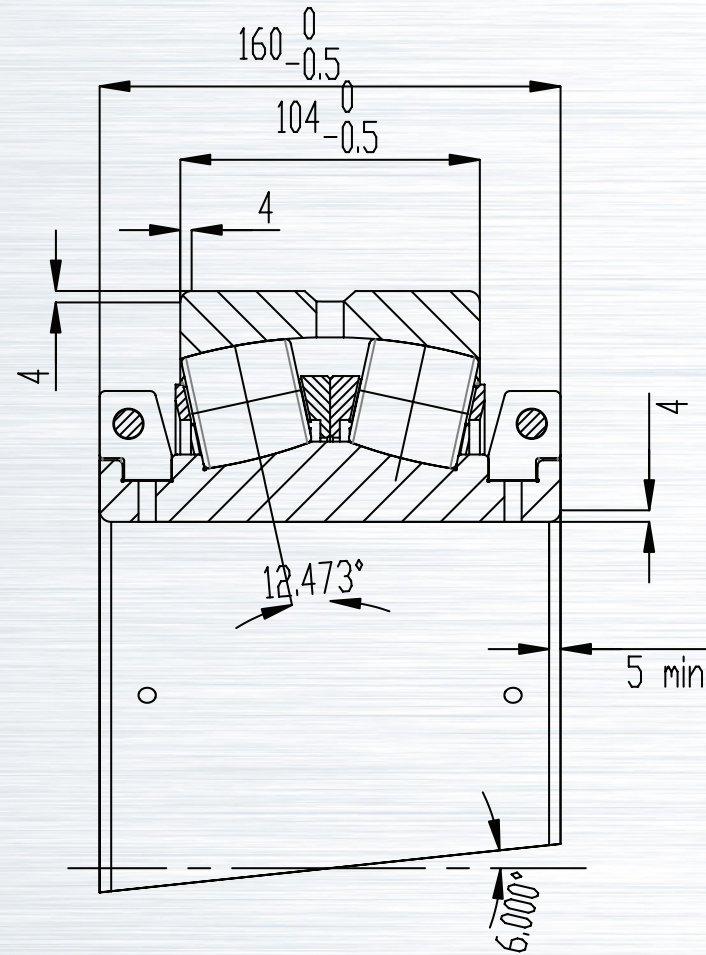
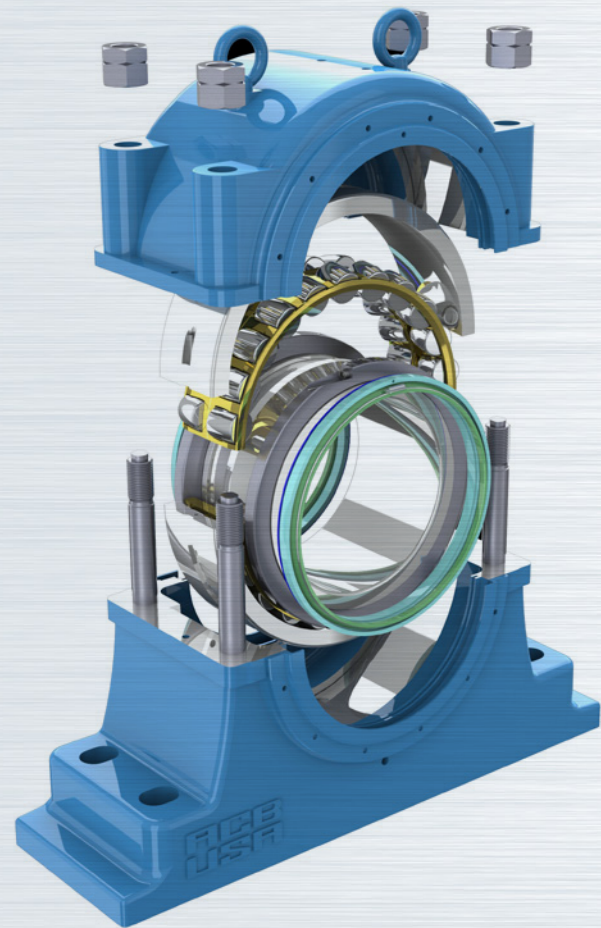

Advantages

- Time saving to replace bearing, specialty in hard-to-access positions.
- Mounting cost reduced
- Downtimes reduced
- Replaces standard solid spherical roller bearings with or without adapter sleeve
- Easily mounted in split pillow block housings

Features

- Multiple bearing component materials available. Ex. rollers, rings and cages
- Installation in customer current housing design
- Bore diameters from 100 mm to 1000 mm
- Special oil or grease sealing and connections
- Different types of bearing engineering coatings

State of the Art

Every single application is treated as a special case and analyzed with the necessary depth accordingly, to provide the most customized solution. There is no limit for bearing customization, from internal geometry to external special coatings.

Applications

Our engineer's vast experience in different industrial fields is what sets us apart.

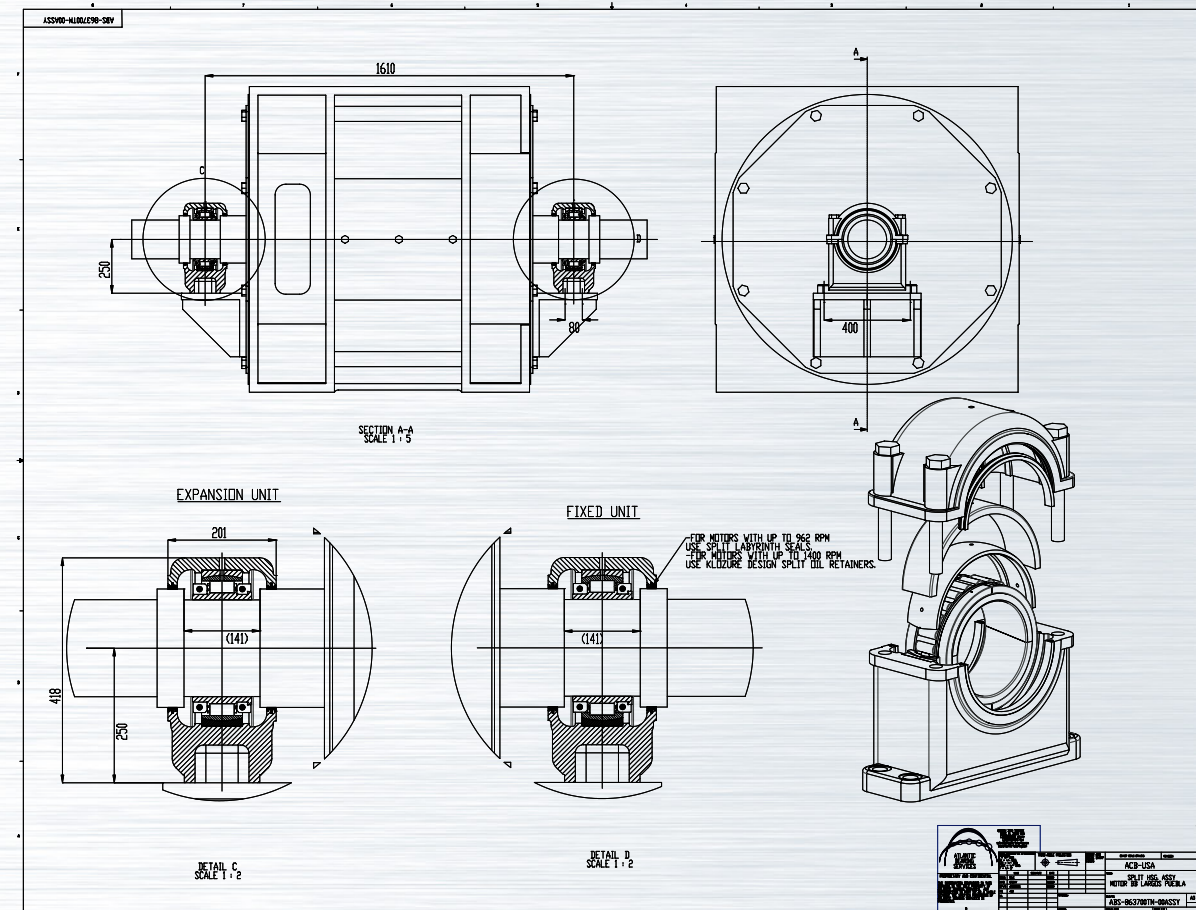

Ex. 5000 HP Synchronous Motor Bearings. Replacing original plain bearing pedestals for triple ring cylindrical roller bearing units.

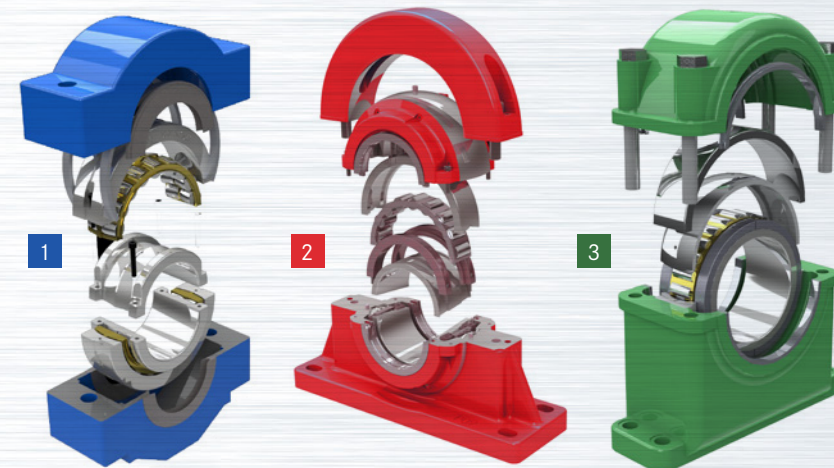

Other split bearing design solutions available upon request.

- Ex.
- 1 - Sealed split spherical roller bearing unit.
 - 2 - Traditional split cylindrical roller bearing with cartridge and pedestal.
 - 3 - Triple ring split cylindrical roller bearing unit.